

WIDER

WiderCat 92



# Contents

## + WiderCat 92

- 8 Introduction
- 12 Future-proof design
- 16 Soul-filled luxury
- 33 General arrangement
- 34 Technical specs

## + Serial Hybrid Propulsion

- 36 Future-ready technology
- 40 Comfort intelligence

## + Wider

- 42 Vision
- 44 Superyachts
- 46 Milestones
- 48 Locations



Crediamo nel progresso e nel potere rivoluzionario della tecnologia. Acceleriamo l'elettrificazione del mondo nautico progettando e realizzando catamarani e superyacht rispettosi dell'ambiente e a prova di futuro.

We believe in progress and the revolutionary power of technology. We are speeding up electrification in the nautical world by designing and building future-proof eco-friendly catamarans and superyachts.

Wir glauben an den Fortschritt und an die revolutionäre Kraft der Technologie. Durch den Entwurf und die Fertigung von umweltgerechten und zukunftsicheren Katamaranen und Superyachten beschleunigen wir die Elektrifizierung der nautischen Welt.

Creemos en el progreso y en el poder revolucionario de la tecnología. Aceleramos la electrificación del mundo náutico, diseñando y realizando catamaranes y superyates que respetan el medio ambiente y se adelantan al futuro.

The  
future  
belongs  
to the  
visionnaires



Hull #01 Launched in January 2024

La visione si trasforma in realtà.  
La prima unità del WiderCat 92 è il precursore in una serie di catamarani d'avanguardia che incarnano un'armoniosa fusione di bellezza, funzionalità, sofisticatezza e innovazione.

Vision turns view.  
The first unit of the WiderCat 92 stands as the trailblazer in a series of avant-garde multihulls embodying a harmonious fusion of beauty, functionality, sophistication, and innovation.

Vision wird zu Realität.  
Das erste Exemplar des WiderCat 92 ist Vorreiter einer Serie von Katamaranen der jüngsten Generation, die eine harmonische Verschmelzung von Schönheit, Funktionalität, Raffinesse und Innovation verkörpern.

La visión se transforma en realidad.  
La primera unidad del WiderCat 92 es el precursor de una serie de catamaranes de vanguardia que encarnan una armoniosa fusión de belleza, funcionalidad, sofisticación e innovación.

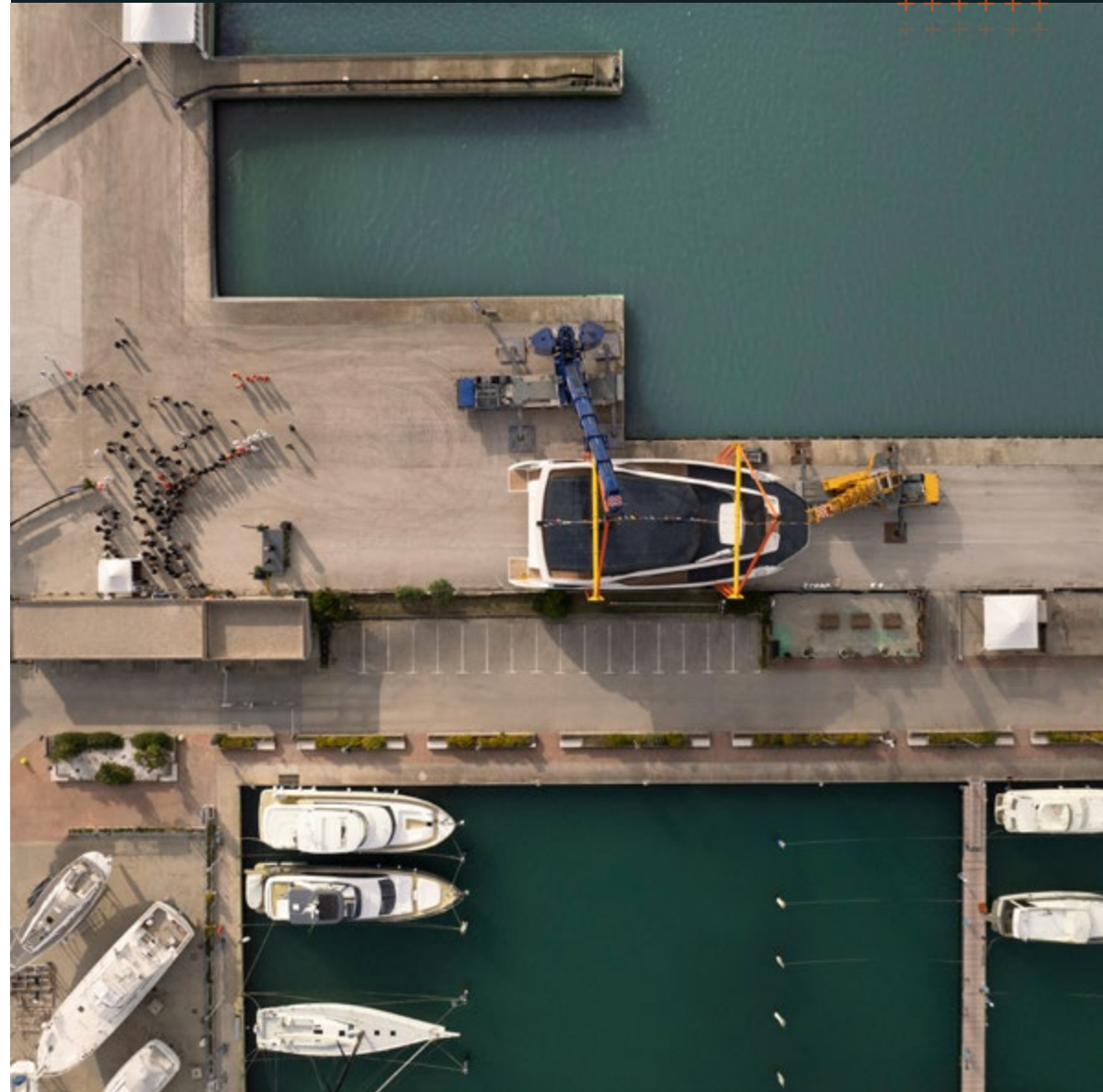

# WiderCat 92

## The Solar Flare



Lasciati abbagliare dal futuro. Da un 28 metri senza limiti di spazio e comfort, combinazione prodigiosa di tecnologia ibrida ed energia solare.

Let yourself be dazzled by the future. By a 28-metre with limitless space and comfort, a remarkable combination of hybrid technology and solar energy.

Lassen Sie die Zukunft auf sich wirken. Sie kommt in Form eines 28 Meter langen Wasserfahrzeugs mit unbegrenztem Raum und Komfort, einer beeindruckenden Kombination aus Hybrid-Technologie und Solarenergie.

Déjate deslumbrar por el futuro: por un modelo de 28 metros, sin límites en términos de espacio o confort, combinación prodigiosa de tecnología híbrida y energía solar.









Muoviti in continuità dalla zona di prua alla spiaggia a poppa. Vivi un'esperienza a pieno contatto con il mare senza lasciare traccia del tuo passaggio. Sperimenta la libertà totale e la pace dei sensi.

It's easy to move from the forward area to the beach club at the stern. Live in full contact with the sea without leaving a trace of your passage. Experience total freedom and peace of mind.

Bewegen Sie sich frei vom Bug bis zum Beach-Bereich im Heck. Erleben Sie den ungefilterten Kontakt mit dem Meer, ohne Spuren Ihrer Reise zu hinterlassen. Genießen Sie völlige Freiheit und Entspannung.

Muévete sin obstáculos desde la zona de proa al beach club de popa. Vive una experiencia en contacto directo con el mar sin dejar ninguna huella a tu paso. Experimenta la libertad total y la paz para los sentidos.



WiderCat 92



# Future proof design

WiderCat 92 è senza limiti perché abbatte i confini tecnologici e le barriere tra spazi esterni e interni, riflettendo un'idea di design in cui convivono estetica e funzionalità, eleganza e innovazione.

WiderCat 92 has no limits. It breaks down technological boundaries and the barriers between outdoor and indoor spaces, reflecting a design concept where aesthetics, functionality, elegance and innovation coexist.

WiderCat 92 ist grenzenlos, denn es überwindet die technologischen Einschränkungen und die Barrieren zwischen Outdoor- und Indoorbereich; es spiegelt eine Designidee wider, die Ästhetik und Funktionalität, Eleganz und Innovation vereint.

WiderCat 92 no tiene límites, porque derriba las fronteras tecnológicas y las barreras entre los espacios internos y externos, reflejo de un concepto del diseño en el que conviven estética y funcionalidad, elegancia e innovación.





Inspired by the sun  
Made for the Earth

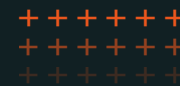

La sovrastruttura si distingue per l'elemento stilistico ad angolo che circonda l'upper deck, affiancato nella zona verso prua dalla linea nel caratteristico Orange Wider.

The superstructure stands out for its stylistic angle feature surrounding the upper deck, coupled with the characteristic Orange Wider line in the area towards the bow.

Der Aufbau zeichnet sich durch das eckige Stilelement rund um das Oberdeck aus, das zum Bug hin von der charakteristischen Linie im Orange Wider begleitet wird.

La superestructura se distingue por el elemento estilístico angular que rodea la cubierta principal, acompañado, en la zona que va hacia la proa, por el perfil en el característico Orange Wider.



Grazie ai 170 mq di pannelli solari installati a bordo, WiderCat 92 è completamente autosufficiente dal punto di vista energetico quando è in rada.

Thanks to 170 m<sup>2</sup> of solar panels installed on-board, WiderCat 92 is completely energy self-sufficient when it lies at anchor in the roadstead.

Dank der 170 m<sup>2</sup> Solarpaneele, die an Bord installiert sind, ist der WiderCat 92 auf Reeden vollkommen energieautark.

Gracias a los 170 m<sup>2</sup> de paneles solares instalados a bordo, WiderCat 92 es completamente autosuficiente desde el punto de vista energético cuando está en la rada.

WiderCat 92



# Soul filled luxury

Comfort, stile, flessibilità d'uso. Il vero lusso è non dover scendere a compromessi, e ogni ambiente di WiderCat 92 è progettato per elevare gli standard dell'esperienza di bordo.

Comfort, style, versatility. The real luxury is not having to compromise, and every WiderCat 92 environment is designed to improve the standards of the on-board experience.

Komfort, Stil, flexible Nutzungsmöglichkeiten. Der wahre Luxus besteht darin, keine Kompromisse eingehen zu müssen: Jedes Ambiente des WiderCat 92 ist für maximale Onboard-Erfahrung gestaltet.

Confort, estilo, flexibilidad de uso. El auténtico lujo es no tener que renunciar a nada: todos y cada uno de los espacios del WiderCat 92 se han diseñado para elevar los estándares de la experiencia a bordo.





———— Main Saloon











———— Main Saloon





Upper Lounge



Le tonalità chiare esaltano la luminosità degli ambienti e le finiture e i materiali di pregio. I particolari in teak si alternano con i dettagli in ebano lucido, per un risultato finale ancora più armonioso ed elegante.

The light hues enhance the luminosity of the interiors as well as the finishing touches and premium materials. Teak accents alternate with glossy ebony details to create a more harmonious and elegant result.

Helle Farbtöne unterstreichen die Helligkeit der Räume sowie die hochwertigen Oberflächen und Materialien. Details aus Teakholz und aus poliertem Ebenholz wechseln sich ab, um ein noch harmonischeres und eleganteres Endergebnis zu erzielen.

Sus tonalidades claras resaltan la luminosidad de los espacios, así como los acabados y materiales exquisitos. Los detalles de teca se alternan con los acabados en ébano brillante, para un resultado final que irradia todavía más armonía y elegancia.





Circa 50mq sono destinati alla cabina armatore, che ha un'ampiezza paragonabile ad un wide body. Ampie vetrate, contatto col mare, versatilità e privacy sono solo alcune delle caratteristiche principali.

Circa 50 m<sup>2</sup> sind für die Eignerkabine bestimmt, deren Geräumigkeit mit einem Wide Body vergleichbar ist. Große Fenster, Kontakt zum Meer, Vielseitigkeit und Privatsphäre sind nur einige der wesentlichen Merkmale.

The owner's cabin measures about 50 m<sup>2</sup>, a size comparable to a wide body. Large windows, full contact with the sea, versatility and privacy are just a few of the main features.

Casi 50 m<sup>2</sup> se destinan al camarote del armador, que tiene una amplitud equiparable a la de un *wide body*. Grandes acristalamientos, contacto con el mar, versatilidad y privacidad son solo algunas de sus características principales.



Owner's Suite



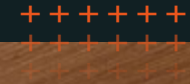

Illuminati a LED, arredati con le firme più prestigiose del Made in Italy e dotati di un sistema ad hoc per il trattamento aria, gli ambienti interni sono espressione di comfort, eleganza e funzionalità.

The indoor areas are an expression of comfort, elegance and functionality, featuring LED lighting, furnishings by the best Made in Italy brands and an ad hoc air treatment system.

LED-Beleuchtung und Einrichtungsgegenstände der renommiertesten Unternehmen des Made in Italy, Ausstattung mit einem speziellen Luftaufbereitungssystem: Die Innenräume sind Ausdruck von Komfort, Eleganz und Funktionalität.

Iluminados con LED, amueblados con las firmas más prestigiosas de la industria italiana y equipados con un sistema personalizado de tratamiento del aire, los interiores transmiten confort, elegancia y funcionalidad.





## Vip Head

Il layout standard prevede due cabine VIP dagli spazi generosi, dotate di una caratteristica unica: l'accesso diretto al beach club, con due piattaforme apribili che assicurano l'accessibilità al mare a tutti gli ospiti.

The standard layout includes two spacious VIP cabins, equipped with a unique feature: direct access to the beach club, with two platforms that can be opened to guarantee every guest access to the sea.

Das Standardlayout umfasst zwei großzügig geschnittene VIP-Kabinen mit einer einzigartigen Besonderheit, dem direkten Zugang zum Beach-Club mit zwei ausklappbaren Plattformen, die allen Gästen Zugang zum Meer ermöglichen.

La distribución estándar prevé dos camarotes vip con mucho espacio, equipados con una característica única: el acceso directo al *beach club*, con dos plataformas abatibles que garantizan la accesibilidad al mar a todos los pasajeros.





Vip Cabin



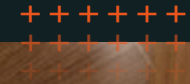

Una terza cabina guest, doppia con bagno privato, completa il layout del lower deck.

A third, twin guest cabin with en-suite bathroom completes the layout of the lower deck.

Eine dritte Doppel-Gästekabine mit eigenem Bad vervollständigt das Layout des Unterdecks.

Un tercer camarote doble para invitados, con baño privado, completa la distribución de la cubierta inferior.









Profile

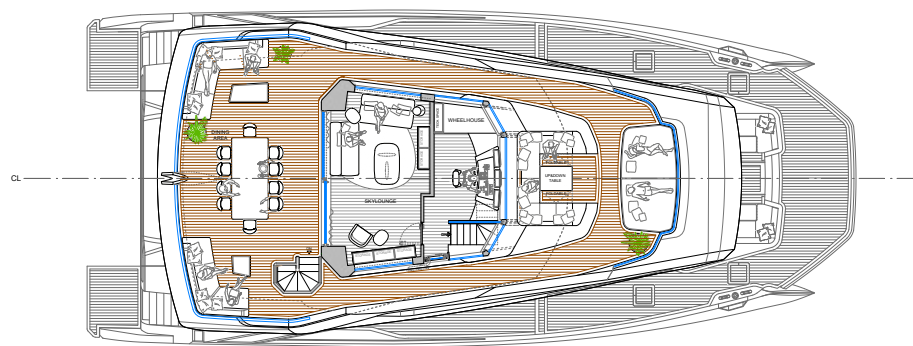

Upper Deck

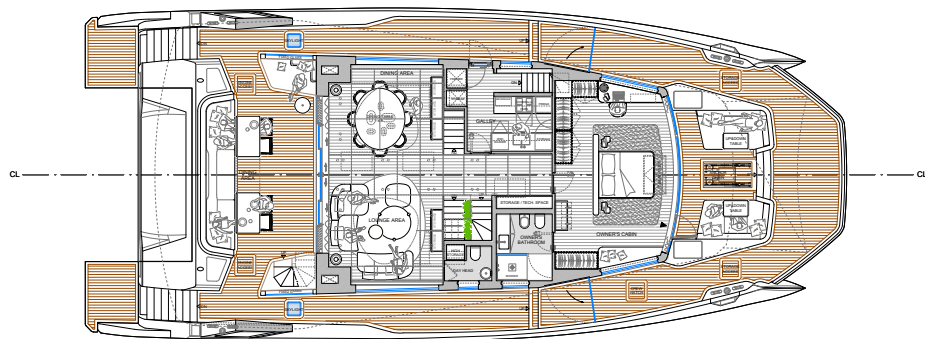

Main Deck

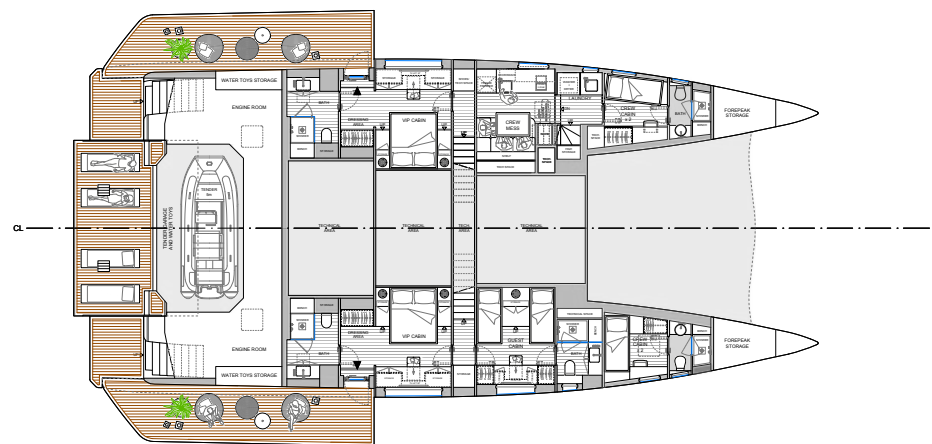

Lower Deck

Costruttore  
Lunghezza (fuori tutto)  
Baglio  
Pescaggio (dislocamento a pieno carico)  
Scafo e sovrastruttura  
Dislocamento a pieno carico  
Stazza lorda  
Designer

Architetto navale  
Interior Designer

Certificazione  
Location

### CAPACITÀ SERBATOI

Carburante  
Acqua

### VELOCITÀ/AUTONOMIA

In condizioni di prova, l'eShaft a doppia elica dotato di sistema ibrido seriale Wider garantisce un'autonomia massima di 2.400 M a 6 nodi

Velocità massima (Electric Boost)  
Velocità di crociera  
Velocità economica  
ZEM  
All'ancora

Gruppo batterie  
Tipo di propulsione  
Motori di propulsione  
Gruppo elettrogeno (velocità variabile)

### STRUTTURA

Scafo semidislocante in vetroresina rinforzata con fibre di carbonio

### POSTI

8 ospiti + 4 membri dell'equipaggio

Builder  
Length (L.O.A.)  
Beam  
Draft (Full Displacement)  
Hull and Superstructure  
Displacement full load  
Gross Tonnage  
Designer

Naval Architect  
Interior Designer

Certification  
Location

### TANK CAPACITIES

Fuel  
Fresh Water

### SPEED/RANGE

An eShaft with twin screw props with Wider Serial Hybrid system allows, in trial condition, a range up to 2,400 nm at 6 knot

Maximum speed (Electric Boost)  
Cruising speed  
Economical Speed  
ZEM  
At Anchor

Battery Bank  
Type of propulsion  
Propulsion motors  
Gen Set (Variable Speed)

### CONSTRUCTION

Semi displacement hull built in GRP + carbon fibre reinforcement

### ACCOMMODATION

8 guests + 4 crew

WIDER srl  
28,04 m (92' 0") approx  
12,00 m (39' 4") approx  
1,65 m (5' 5") approx  
GRP + CRP  
113,5 tons approx  
242 GT  
Luca Dini Design  
Centro Stile Wider  
Wider Engineering & MDS Engineering  
Luca Dini Design  
Centro Stile Wider  
CE Category A  
Fano (Italy)

10000 L - 2,640 US gal  
2,880 L - 760 US gal

	Range nm
14 knots	
12 knots	600 approx
8 knots	1.600 approx
up to 6 knots	4.5 hours @6knots approx
	12 hours approx

360 kW available  
eShaft with twin screw props  
2 x 500 kW Danfoss Editron PM Motor  
2 x 349 kW FPT N67 + Danfoss Editron

Preliminary - not binding

Hersteller  
 Länge (über alles)  
 Tragbalken  
 Tiefgang (Vollverdränger)  
 Schiffskörper und Aufbau  
 Vollverdränger  
 Bruttoreaumzahl  
 Designer

Schiffbauingenieur  
 Innenarchitekt

Zertifizierung  
 Standort

### TANKGRÖSSEN

Kraftstoff  
 Wasser

### GESCHWINDIGKEIT/AUTONOMIE

Unter Testbedingungen garantiert der mit dem seriellen Wider-Hybridsystem ausgestattete eShaft mit zwei Propellern eine maximale Autonomie von 2400 NM bei 6 Knoten

Max. Geschwindigkeit (Elektroschub)  
 Reisegeschwindigkeit  
 Marschfahrt  
 ZEM  
 Vor Anker

Batteriepack  
 Antriebsart  
 Antriebsmotoren  
 Stromaggregat (variable Geschwindigkeit)

### KONSTRUKTION

Halbverdränger-Schiffskörper aus  
 Glasfaserkunststoff, verstärkt mit Carbonfaser

### PLÄTZE

8 Gäste + 4 Crewmitglieder

Constructor  
 Eslora (total)  
 Manga  
 Calado (desplazamiento a plena carga)  
 Casco y superestructura  
 Desplazamiento a plena carga  
 Arqueo bruto  
 Diseñador

Ingeniero náutico  
 Diseñador de interiores

Certificación  
 Ubicación

### CAPACIDAD DE LOS DEPÓSITOS

Combustible  
 Agua dulce

### VELOCIDAD/AUTONOMÍA

En condiciones de ensayo, el eShaft de doble hélice equipado con sistema híbrido de serie Wider garantiza una autonomía máxima de 2 400 m a 6 nudos

Velocidad máxima (Electric Boost)  
 Velocidad de crucero  
 Velocidad económica  
 ZEM  
 Fondeado

Grupo de baterías  
 Tipo de propulsión  
 Motores de propulsión  
 Grupo electrógeno (velocidad variable)

### ESTRUCTURA

Casco de semidesplazamiento de fibra de vidrio reforzada con fibra de carbono

### PLAZAS

8 pasajeros + 4 miembros de la tripulación

WIDER srl  
 28,04 m (92' 0") approx  
 12,00 m (39' 4") approx  
 1,65 m (5' 5") approx  
 GRP + CRP  
 113,5 tons approx  
 242 GT  
 Luca Dini Design  
 Centro Stile Wider  
 Wider Engineering & MDS Engineering  
 Luca Dini Design  
 Centro Stile Wider  
 CE Category A  
 Fano (Italy)

10000 L - 2,640 US gal  
 2,880 L - 760 US gal

		<b>Range nm</b>
14 knots		
12 knots		600 approx
8 knots		1.600 approx
up to 6 knots		4.5 hours @6knots approx
		12 hours approx

360 kW available  
 eShaft with twin screw props  
 2 x 500 kW Danfoss Editron PM Motor  
 2 x 349 kW FPT N67 + Danfoss Editron

Preliminary - not binding

# Serial Hybrid Propulsion

Anche sul WiderCat 92 trova posto il sistema ibrido seriale di Wider, che ha trasferito tutto il suo know-how tecnico sviluppato nella superyacht division in modo altrettanto efficiente su una scala più piccola.

WiderCat 92 incorporates Wider's serial hybrid system which, on a smaller scale but just as efficiently, builds on the shipyard's extensive technical know-how in the Superyacht division.

Auch an Bord des WiderCat 92 ist Platz für das serielle Hybridsystem von Wider, das hier sein gesamtes technisches Know-how, das in der Superyacht-Division entwickelt wurde, ebenso effizient auf einen kleineren Maßstab übertragen hat.

En el WiderCat 92 también tiene cabida el sistema híbrido de serie de Wider, que ha trasvasado todos sus conocimientos técnicos desarrollados en la división de superyates de una forma igual de eficiente, a menor escala.

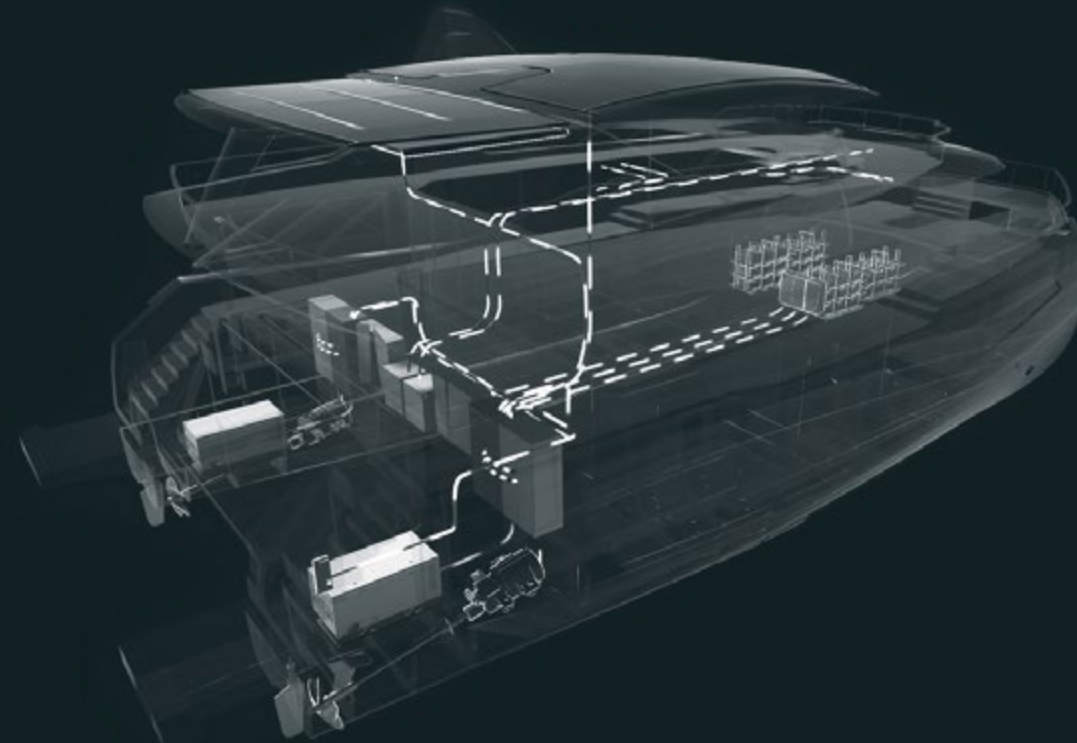

Alle eliche sono collegati solo ed esclusivamente i motori elettrici con tecnologia Permanent Magnets con una potenza massima di 583kW ciascuno. La produzione di energia è affidata a due generatori a giri variabili della potenza di 349 kW ciascuno, costituiti da due motori endotermici FPT modello N67 570 EVO. L'energia è stoccata in 30 batterie con chimica LiFePO4 (Litio Ferro Fosfato) gestite da un avanzato Wider Power Management System, in grado di monitorare costantemente tutti i parametri di esercizio delle stesse.

The propellers are only and exclusively connected to the electric motors with Permanent Magnet technology delivering 583 kW maximum power each. Energy production is entrusted to two generators with variable rpm featuring 349 kW power each, consisting in two N67 570 EVO endothermic FPT engines. Energy is stored in 30 LiFePO4 (Lithium Iron Phosphate) batteries managed by a state-of-the-art Wider Power Management System that constantly monitors operating parameters.

An die Propeller sind ausschließlich Elektromotoren mit Permanentmagnet-Technologie und einer maximalen Leistung von jeweils 583 kW angeschlossen. Für die Energieerzeugung kommen zwei Generatoren mit variabler Drehzahl zu je 349 kW zum Einsatz, die aus zwei endothermen Motoren des Typs FPT, Modell N67 570 EVO, bestehen. Die Energie wird in 30 Batterien mit LiFePO4-Chemie (Lithium-Eisen-Phosphat) gespeichert, die von einem modernen Wider Energiemanagementsystem verwaltet werden, das in der Lage ist, alle ihre Betriebsparameter konstant zu überwachen.

A las hélices van conectados, única y exclusivamente, los motores eléctricos con tecnología *Permanent Magnets*, con una potencia máxima de 583 kW cada uno. La producción de energía se confía a dos generadores con revoluciones variables y una potencia de 349 kW cada uno, formados por dos motores endotérmicos FPT modelo N67 570 EVO. La energía se almacena en 30 baterías con química LiFePO4 (litio-ferrofosfato) gestionadas mediante un avanzado Sistema de Gestión de la Potencia Wider, capaz de monitorizar de forma constante todos sus parámetros de funcionamiento.

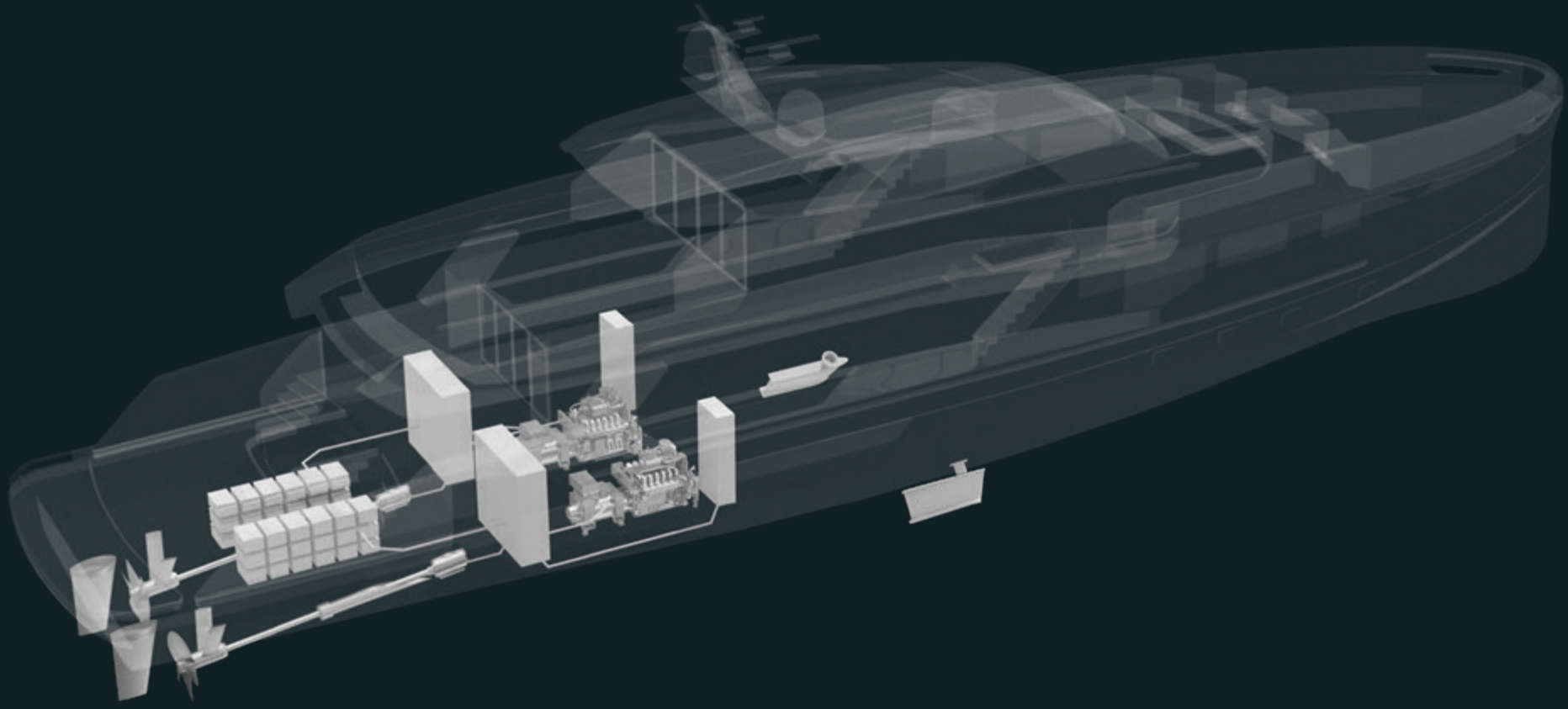

# 01

## Zero Vibrations

+

L'assenza di una trasmissione rigida garantisce una navigazione in totale comfort e relax.

The lack of a rigid drive train guarantees comfortable and totally relaxing navigation.

Der Verzicht auf ein starres Übertragungssystem gewährleistet Navigation im Zeichen von Komfort und Entspannung.

La ausencia de una transmisión rígida garantiza una navegación con total confort y tranquilidad.

# 02

## Less Noise

+

I rumori si azzerano completamente quando l'energia viene erogata dalle sole batterie.

When powered by just the batteries, all noise is completely eliminated.

Geräusche werden vollständig beseitigt, wenn die Stromversorgung nur über die Batterien erfolgt.

Los ruidos se eliminan por completo cuando la energía suministrada procede solo de las baterías.

## Comfort Intelligence





# 03

## More Space

+

La flessibilità del design della sala macchine permette di ottenere più spazio nella parte centrale dello scafo.

The flexibility of the engine room design means there is more space available in the central part of the hull.

Die flexible Gestaltung des Maschinenraums bietet mehr Platz im mittleren Teil des Rumpfes.

La flexibilidad del diseño de la sala de máquinas permite obtener más espacio en la parte central del casco.

# 04

## Tailored setup

+

La strategia di gestione dell'energia a bordo è completamente personalizzabile in base alle richieste dell'Armatore.

The energy management strategy used on-board can be completely customised according to the Owner's demands.

Die Energiemanagementstrategie an Bord lässt sich vollständig an die Anforderungen des Eigners anpassen.

La estrategia de gestión de la energía a bordo es completamente personalizable en base a las necesidades del armador.

An aerial photograph of a river system, likely a dam or a large-scale water management project. The image is heavily color-graded with shades of teal, cyan, and dark blue. The river flows from the top left towards the bottom right, with a prominent structure (possibly a dam or a large bridge) visible in the upper left quadrant. The surrounding landscape is rugged and appears to be a mix of natural terrain and human-made structures. The overall mood is serene yet powerful, emphasizing the scale of the water management project.

# The Wider Vision



+

Architetti del futuro. Ingegnosi e solidi. Dirompenti in ogni approccio, dal design all'ingegnerizzazione, c'è soltanto un obiettivo a cui puntiamo: restringere il divario tra presente e futuro.

Architects of the future. Ingenious and reliable. Every approach is revolutionary, from the design to the engineering, there is only one goal: narrow the gap between present and future.

Architekten der Zukunft. Erfindungsreich und konkret. Vom Design bis zum Engineering verfolgen wir mit unseren bahnbrechenden Ansätzen nur ein Ziel: Die Kluft zwischen Gegenwart und Zukunft zu verringern.

Arquitectos del futuro. Ingeniosos y experimentados. Disruptivos desde cualquier enfoque, desde el diseño a la ingeniería, solo tenemos un objetivo: acercar la brecha entre el presente y el futuro.

# Superyachts



Le grandi sfide hanno bisogno di grandi e dedicate soluzioni. Oltre ai catamarani, Wider progetta e costruisce superyacht multipremiati che combinano una propulsione ibrida seriale iper efficiente - la prima ad essere stata usata nella nautica da diporto - con ampi spazi a bordo. E un'inconfondibile maestria italiana.

Große Herausforderungen benötigen große und spezielle Lösungen. Neben Katamaranen entwirft und baut Wider auch vielfach preisgekrönte Superyachten. Hierbei wird – erstmals in der Freizeitschiffahrt – ein hocheffizienter serieller Hybridantrieb mit besonderer Geräumigkeit an Bord vereint. Und nicht zu vergessen: unverwechselbare italienische Handwerkskunst.

Big challenges need big and dedicated solutions. As well as catamarans, Wider designs and builds multiple award-winning superyachts that combine hyper-efficient serial hybrid propulsion –the first to be used in pleasure yachting– with large spaces on-board, featuring unmistakable Italian craft.

Los grandes retos necesitan soluciones grandes que sean también específicas. Aparte de catamaranes, Wider diseña y construye superyates galardonados con múltiples premios, que combinan una propulsión híbrida de serie supereficiente –la primera que se ha utilizado en barcos de recreo– con amplios espacios a bordo y la inconfundible maestría italiana.

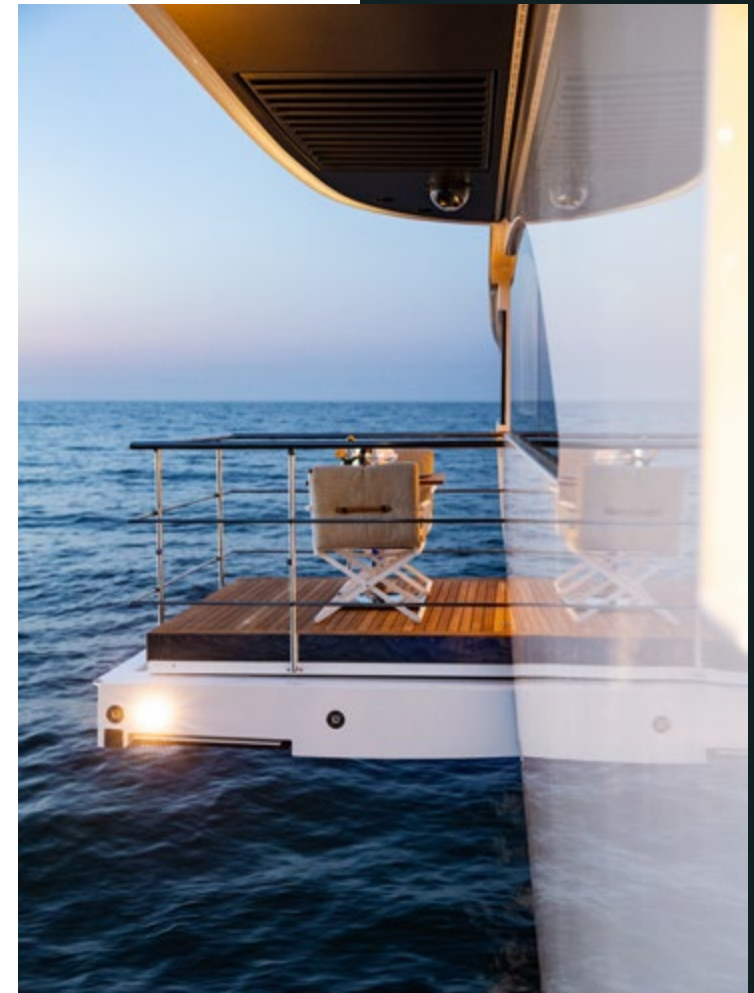

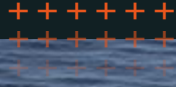

## + 2011

Wider presenta Wider 150, il primo superyacht equipaggiato con sistema di propulsione ibrido seriale.

Wider presents Wider 150, the first superyacht equipped with a serial hybrid propulsion system.

Wider präsentiert Wider 150, die erste Superyachten mit seriellem Hybridantriebssystem.

Wider presenta Wider 150, el primer superyate equipado con sistema de propulsión híbrida de serie.

## + 2014

Wider presenta Wider 165 e Wider 32, vincitori entrambi dell'AIM Marine Group Editor's Choice.

Wider presents Wider 165 and Wider 32, both winners of the AIM Marine Group Editor's Choice.

Wider präsentiert Wider 165 und Wider 32, die beide mit dem AIM Marine Group Editor's Choice ausgezeichnet werden.

Wider presenta Wider 165 y Wider 32, ambos ganadores del premio AIM Marine Group Editor's Choice.

## + 2010

Nasce Wider. Il Wider 42 spopola grazie al suo sistema brevettato di ampliamento del pozzetto.

Wider is established. Wider 42 is all the rage thanks to its patented expanding cockpit.

Wider wird gegründet. Wider 42 wird dank des patentierten Systems zur Cockpitverlängerung ein großer Erfolg.

Nace Wider. El Wider 42 se populariza gracias a su sistema patentado de ampliación de la bañera.

## + 2012

Il Wider 42 vince l'ADI Design Index, l'AIM Marine Group Editor's Choice e il Best of the Best di Robb Report.

Wider 42 wins the ADI Design Index, the AIM Marine Group Editor's Choice and the Best of the Best by Robb Report.

Wider 42 gewinnt den ADI Design Index, die AIM Marine Group Editor's Choice und den Best of the Best von Robb Report.

El Wider 42 gana el ADI Design Index, el AIM Marine Group Editor's Choice y el Best of the Best de Robb Report.

## + 2015

Wider 150 è il primo M/Y ad ottenere la certificazione RINA Comfort Class con punteggio 100/100.

Wider 150 is the first M/Y to be awarded RINA Comfort Class certification with the score 100/100.

Wider 150 ist die erste M/Y, die das RINA Comfort Class Zertifikat mit 100/100 Punkten erhält.

Wider 150 es el primer megayate en obtener la certificación RINA Comfort Class con una puntuación de 100/100.

# + 2018

Wider 165 vince il RINA Comfort Class con 100/100, il RINA Green Plus Platinum e il World Superyacht Award.

Wider 165 wins the RINA Comfort Class with 100/100, the RINA Green Plus Platinum and the World Superyacht Award.

Wider 165 gewinnt die RINA Comfort Class mit 100/100 Punkten, die RINA Green Plus Platinum sowie den World Superyacht Award.

Wider 165 gana el RINA Comfort Class con 100/100, el RINA Green Plus Platinum y el World Superyacht Award.

# + 2022

Wider presenta WiderCat 92 e il superyacht Moonflower 72.

Wider presents WiderCat 92 and superyacht Moonflower 72.

Wider präsentiert WiderCat 92 und die Superyachten Moonflower 72.

Wider presenta WiderCat 92 y el superyate Moonflower 72.

# + 2019

L'acquisizione di Wider da parte di Marcello Maggi segna l'inizio di un nuovo capitolo nella storia del cantiere.

The purchase of Wider by Marcello Maggi marks the start of a new chapter in the history of the shipyard.

Die Übernahme von Wider durch Marcello Maggi markiert den Beginn eines neuen Kapitels in der Geschichte der Werft.

La adquisición de Wider por parte de Marcello Maggi señala el inicio de un nuevo capítulo en la historia del astillero.

# + 2023

Wider svela WiLder 60, un superyacht che incarna il non plus ultra in termini di eccellenza e artigianalità. Inaugurazione del nuovo cantiere Vision Hub dedicato alla costruzione di yacht in vetroresina a Fano.

Wider unveils WiLder 60, a superyacht embodying the ultimate in excellence and craftsmanship. Inauguration of the new Vision Hub GRP yacht building facility in Fano.

Wider präsentiert die WiLder 60, eine Superyacht, die das Nonplusultra an Exzellenz und Handwerkskunst verkörpert. Einweihung der neuen Vision Hub GFK-Yachtbauanlage in Fano.

Wider presenta WiLder 60, un superyate que encarna lo último en excelencia y artesanía. Inauguración en Fano de Vision Hub, las nuevas instalaciones de construcción de yates de fibra de vidrio (GRP).



→ Fano - Venice - Monaco

# Locations

Offices and  
production plants





Ancorata nelle Marche, regione con una ricca tradizione nautica, Wider ha ampliato i suoi orizzonti a livello mondiale grazie al nuovo cantiere avveniristico di Fano, al Superyacht Hub di Venezia, all'ufficio commerciale di Monaco e a una rete di dealer in costante espansione.

Anchored in Marche, a region of Italy with a rich maritime heritage, Wider has extended its reach across the world with its new, futuristic facility in Fano, the Superyacht Hub in Venice, a commercial office in Monaco and a constantly expanding network of dealers.

Wider ist in den Marken verankert, einer Region Italiens mit einem reichen maritimen Erbe. Mit seiner neuen, futuristischen Anlage in Fano, dem Superyacht Hub in Venedig, einem Handelsbüro in Monaco und einem ständig wachsenden Händlernetz hat es seine Reichweite auf die ganze Welt ausgedehnt.

Anclada en Las Marcas, una región italiana con gran tradición marítima, Wider ha extendido su alcance por todo el mundo con sus nuevas y futuristas instalaciones en Fano, el Superyacht Hub de Venecia, una oficina comercial en Mónaco y con una red de concesionarios en constante expansión.



## Legal notice

---

1. This Brochure shall not constitute in any circumstances whatsoever any offer by the shipyard to any person or be incorporated into any contract.
2. Any and all information contained in this Brochure, including without limitation all technical data, performance, illustrations and drawings, are not contractual and refer to European standards models of the super yachts built by the shipyard and have been up-dated by the shipyard as of the date of issue of the Brochure. The only valid technical reference or description is the specific parameter of each super yacht cited only on purchase of the same. Therefore the only indication binding on the seller are contained solely in the sale agreement and in the relevant specific manual.

This Brochure is based on information available at the date of issue. Notwithstanding all efforts to insure accuracy, the information contained in the Brochure may not cover all details, subsequent changes, nor accurately foresee or report all possible scenarios. Displays, photos, schemes, designs or examples contained in the Brochure are solely and exclusively reproduced to highlight the information contained. The shipyard declines any and all liability for any use thereof on the basis of the information contained in the Brochure.

3. The Brochure and its contents may not be copied or reproduced, in whole or in part, and may not be modified, changed or altered in any way, shape or form, whether in whole or in part.
4. The sale of this Brochure is not authorized.

## Shipyards

---

**Wider Srl a socio unico**  
Via Matteo Nuti, 4  
61032 Fano (PU), Italy

**Superyacht Hub**  
Via dell'Elettricità, 15/17  
30175 Venezia (VE), Italy

**Wider Vision Hub**  
Via Pilo Biancalana  
61032 Fano (PU), Italy

## Info

---

Tel. +39 0721 1840031  
[questions@wider-yachts.com](mailto:questions@wider-yachts.com)

[wider-yachts.com](http://wider-yachts.com)

## Social

---



